

33048

T-SECTION 88
 1233.43 GR/M
 W.T = 15 mm

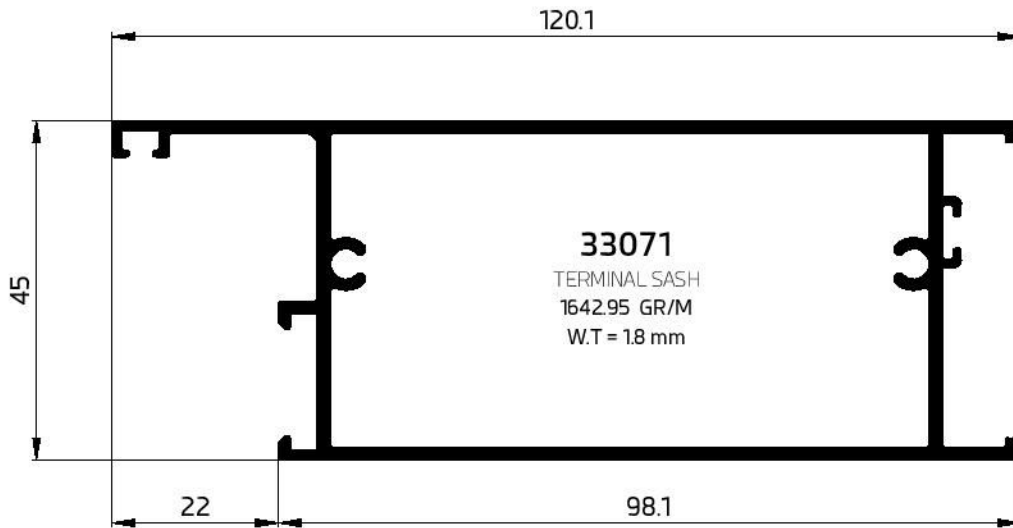

33071

TERMINAL SASH
 1642.95 GR/M
 W.T = 18 mm

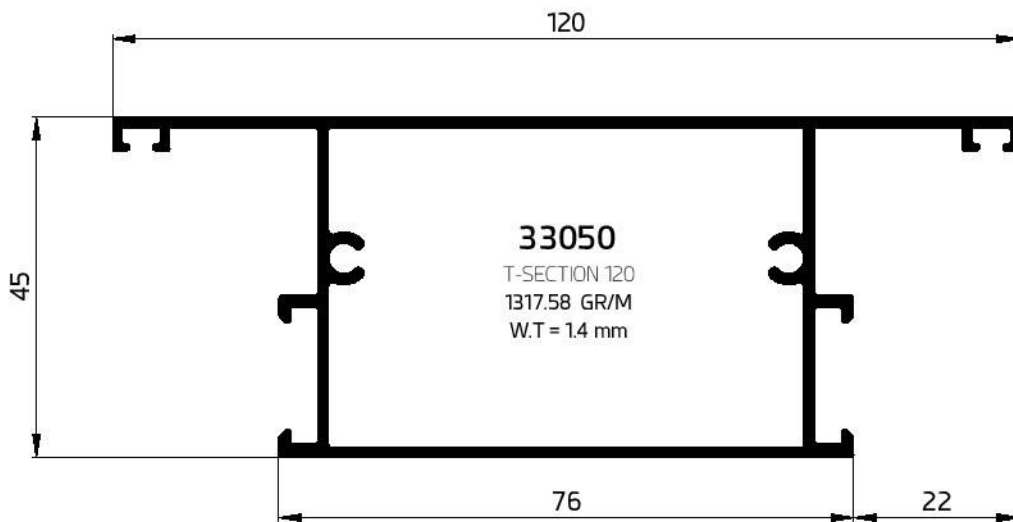

33050

T-SECTION 120
 1317.58 GR/M
 W.T = 1.4 mm

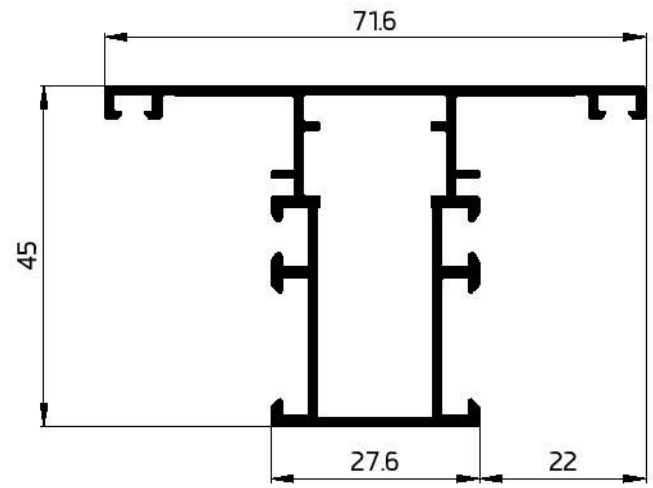
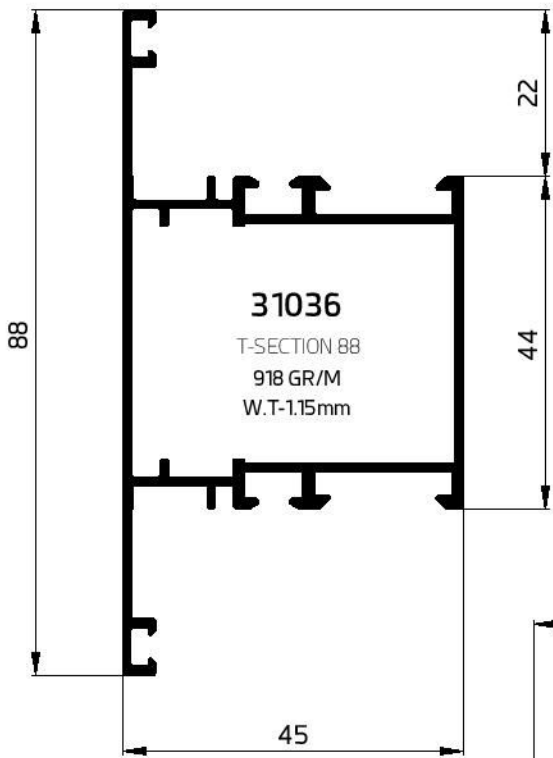
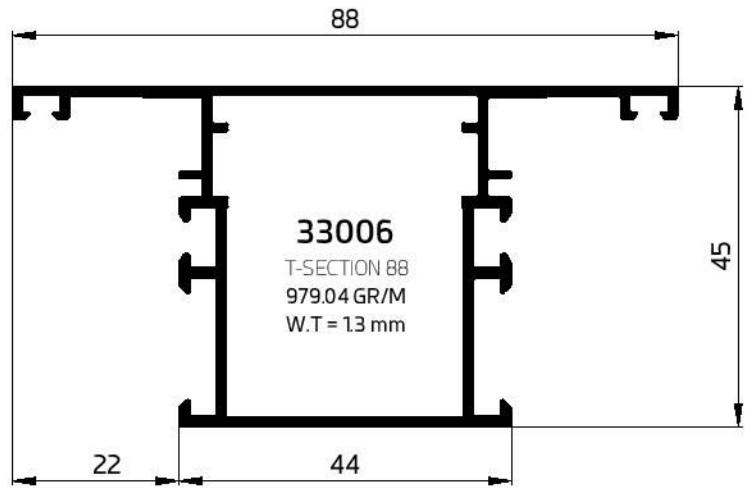
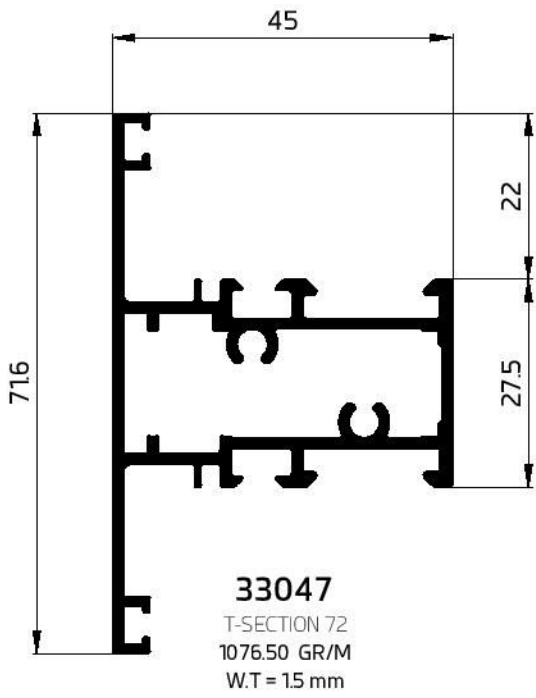

33094
T-SECTION 72
915 GR/M
W.T-15mm

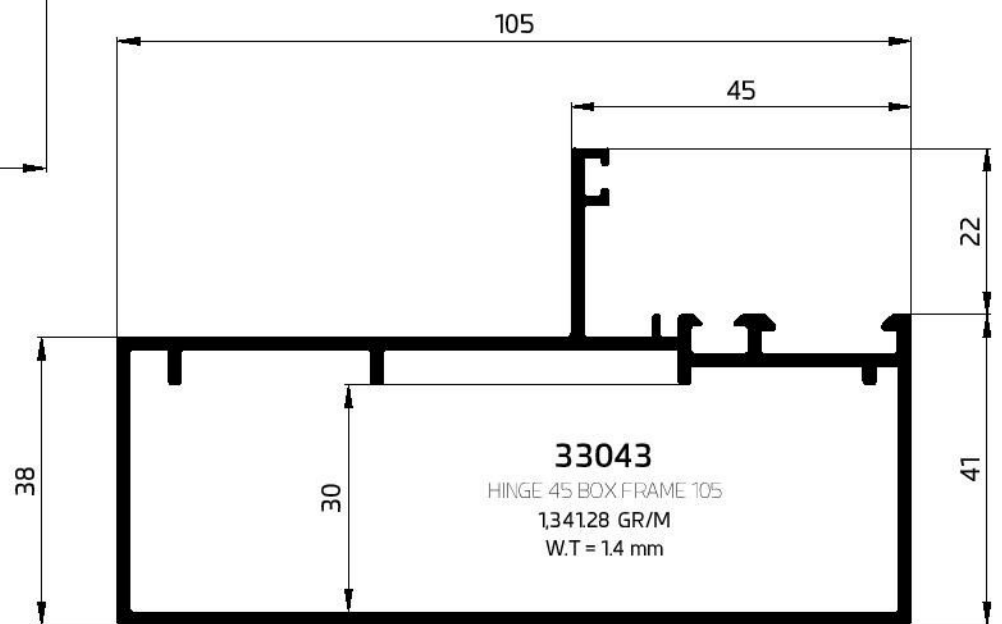

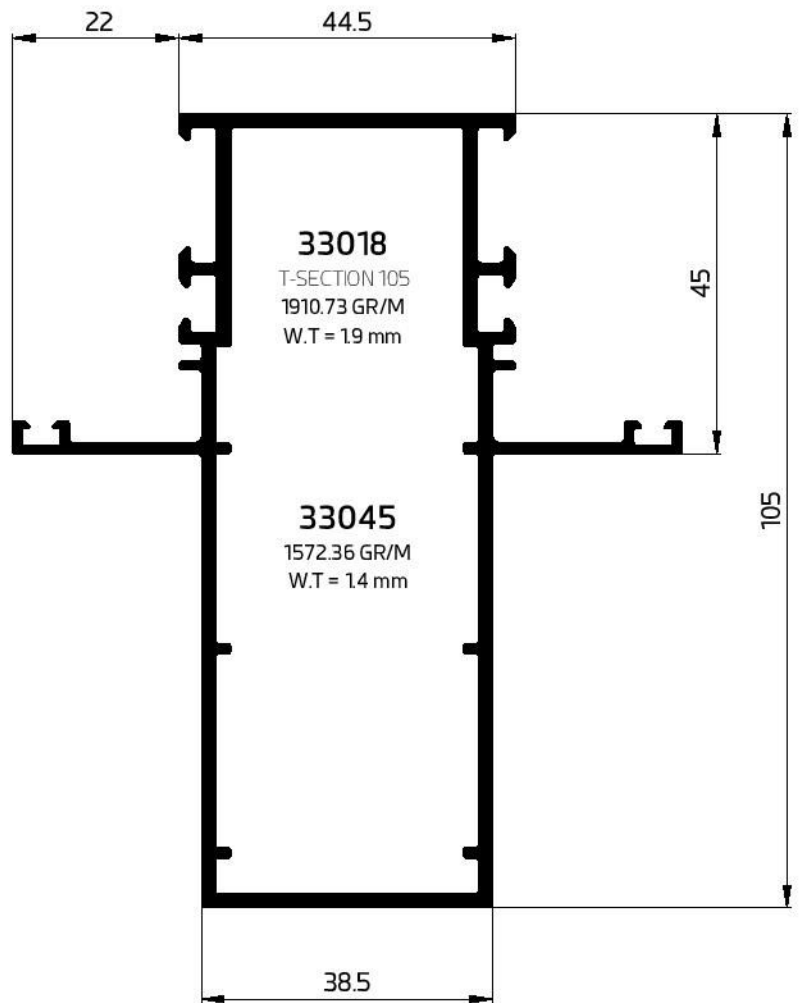
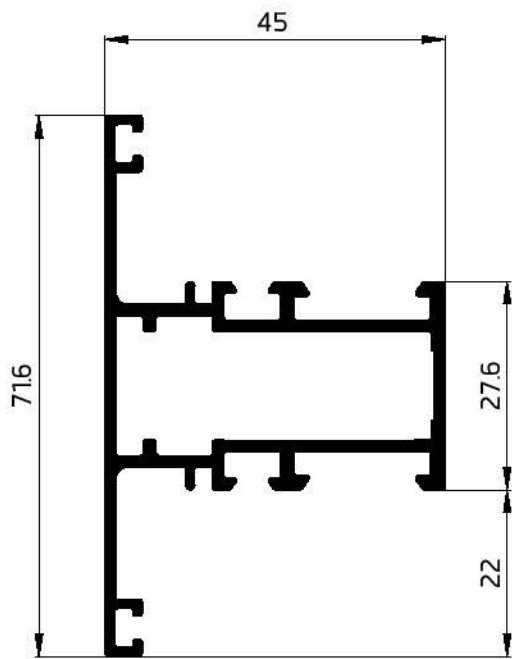
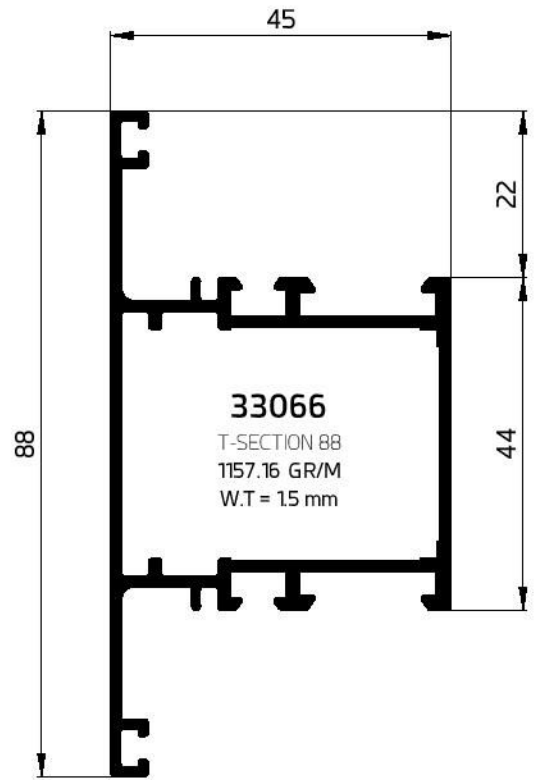
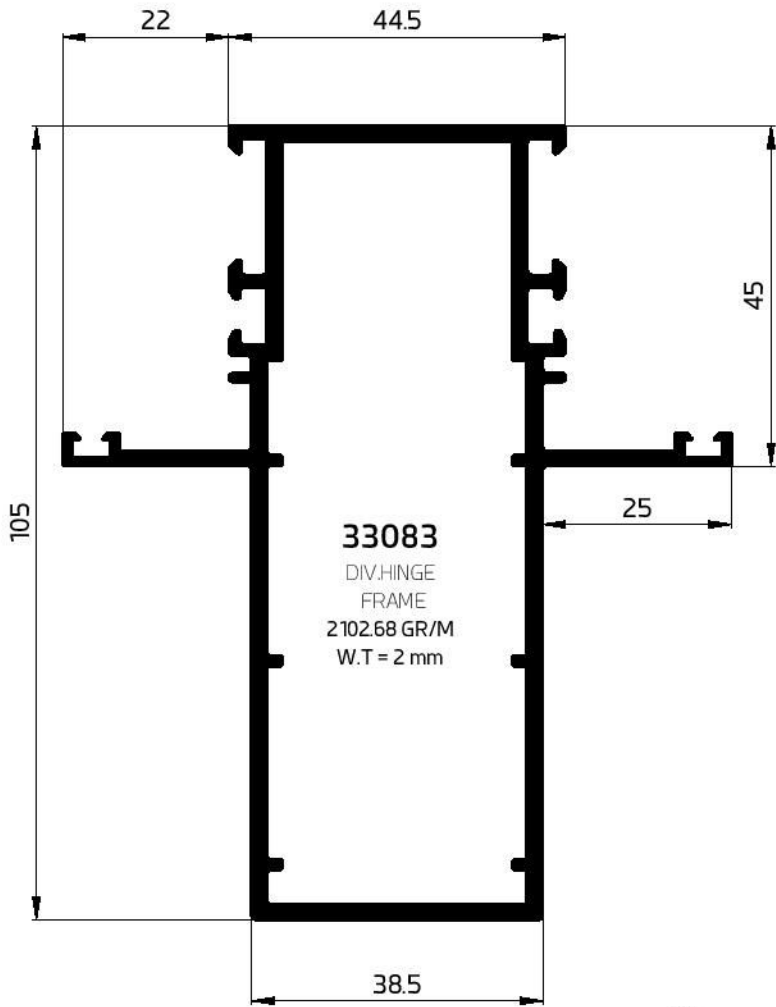

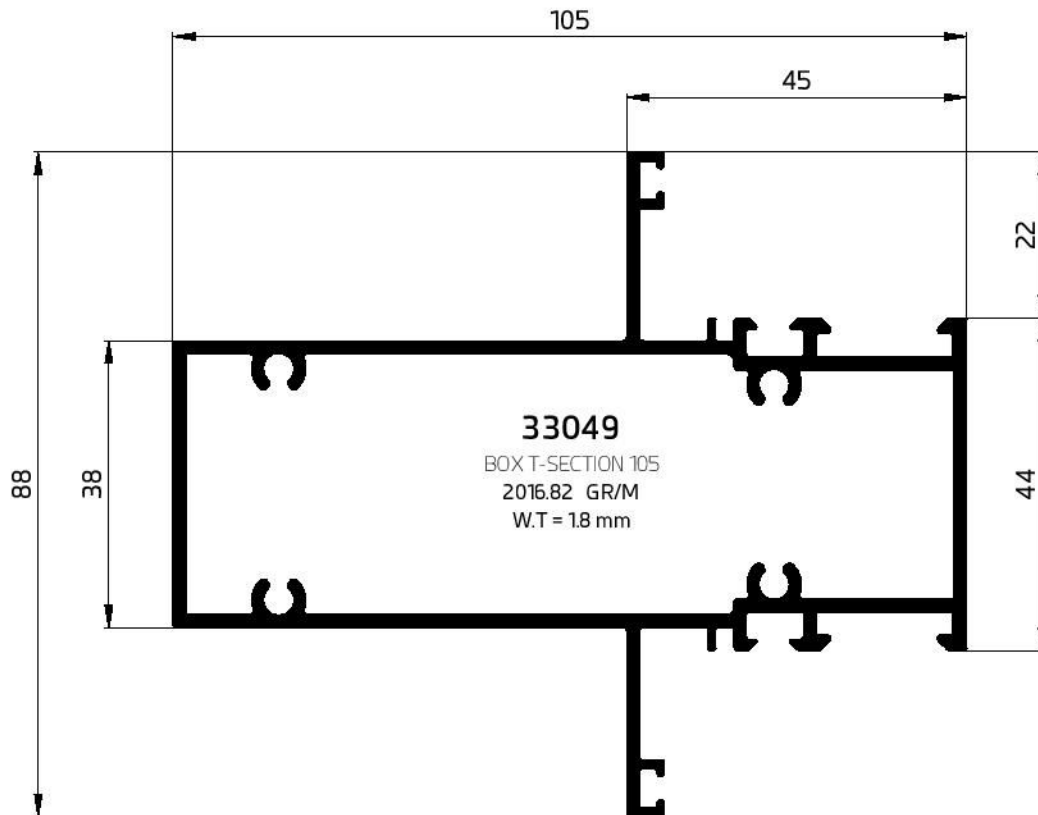
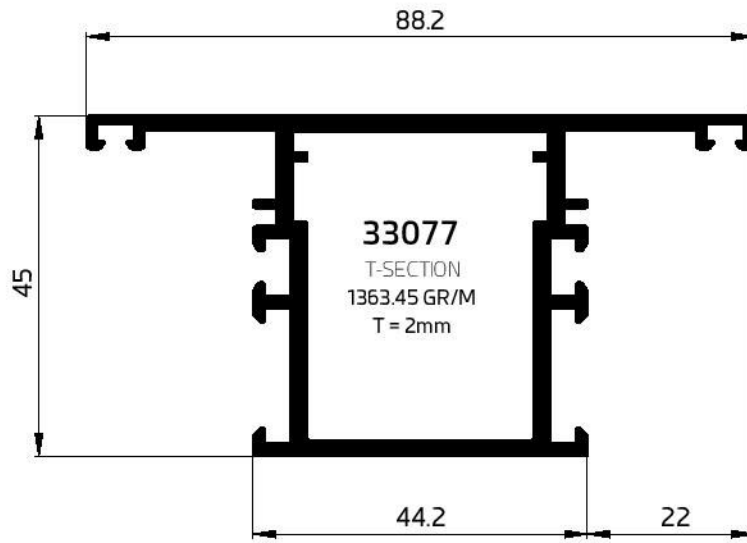

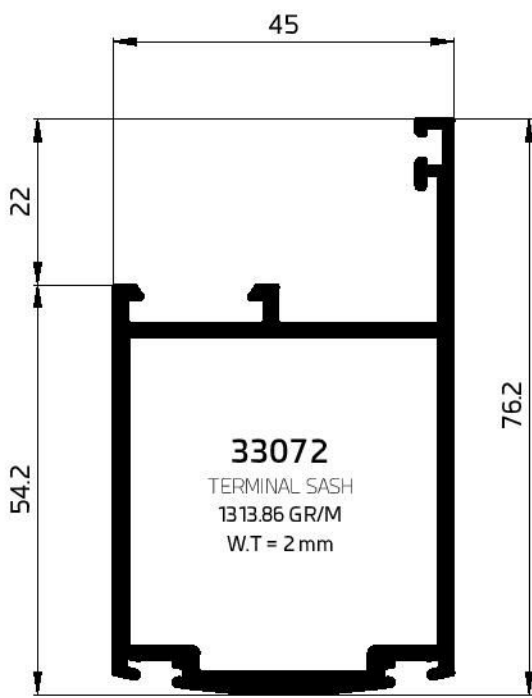
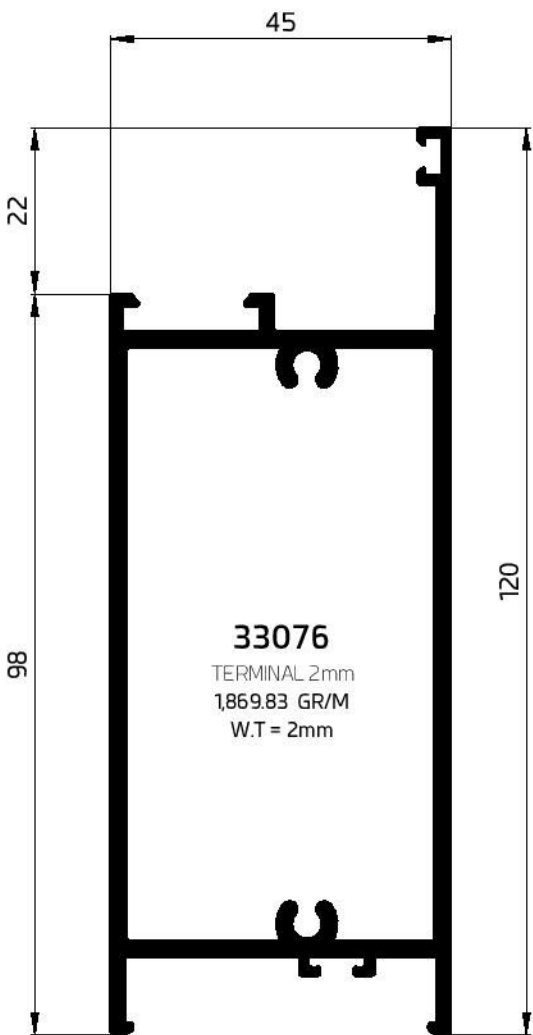
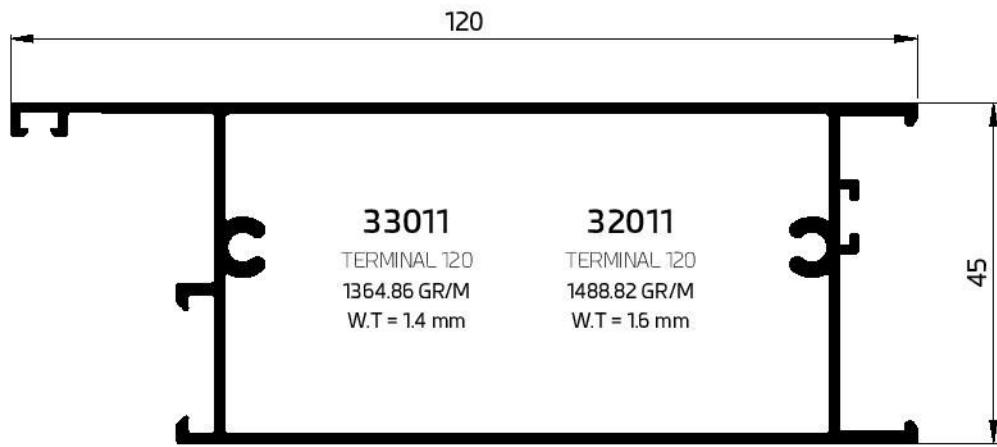

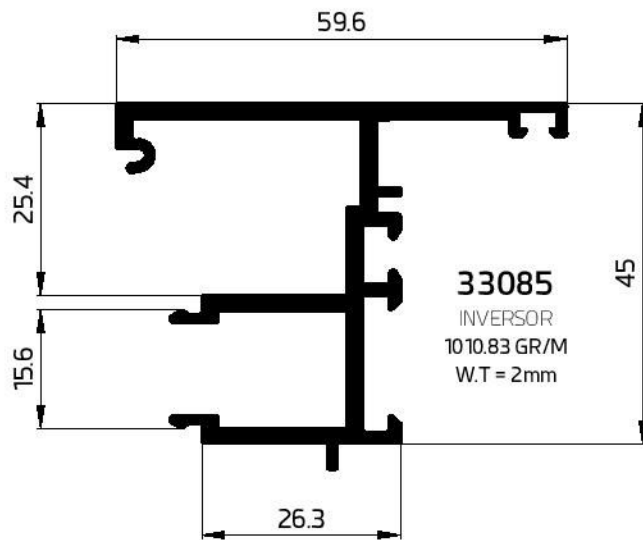
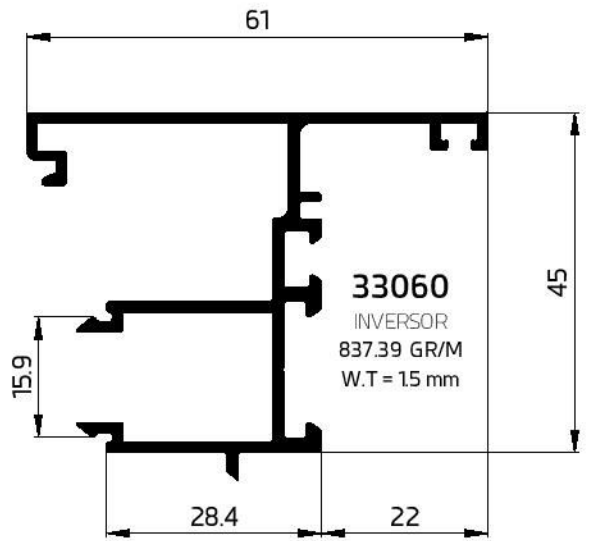
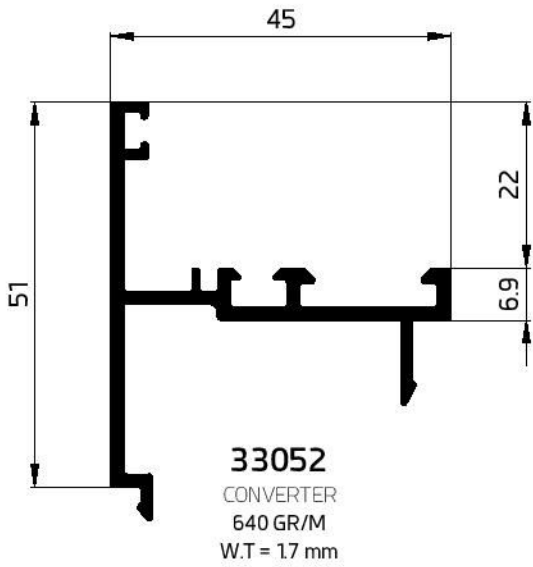
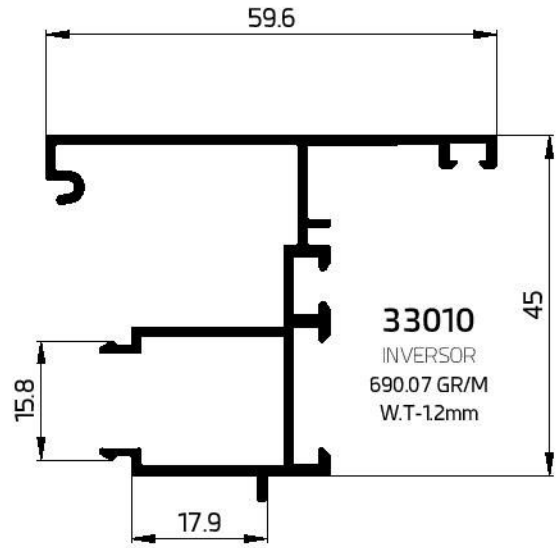
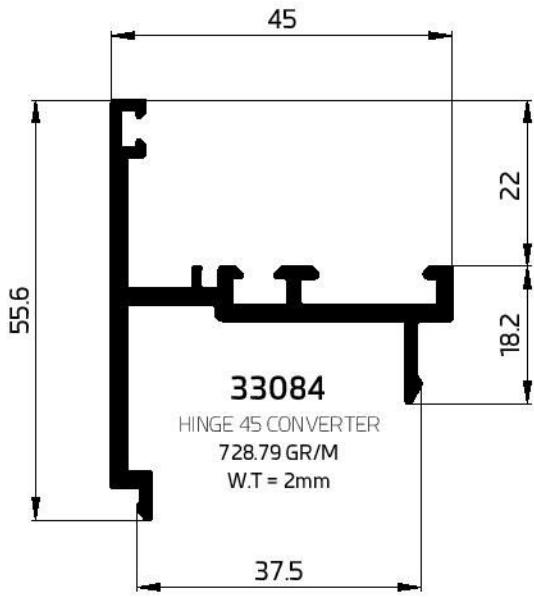

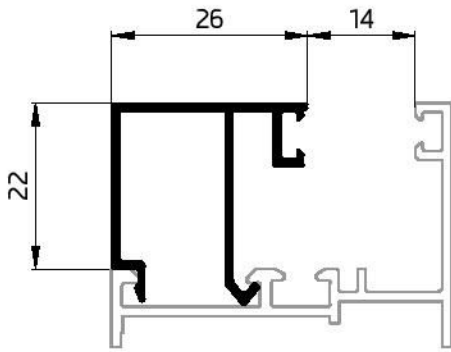

33021

BEAD 22x26
295.50 GR/M
W.T-12mm

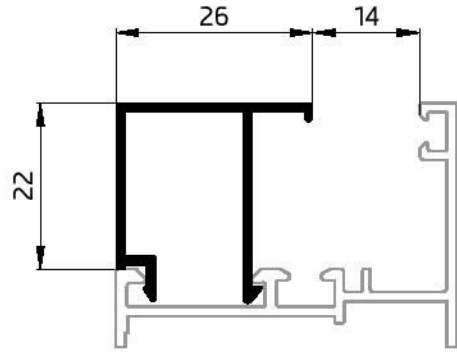

33054

BEAD 22x26
286.70 GR/M
W.T = 13 mm

33154

BEAD 22x26
264.3 GR/M
W.T = 1.15 mm

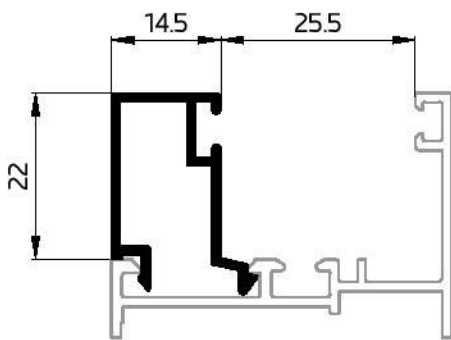

33055

BEAD 22x14.5
260.29 GR/M
W.T = 12 mm

33155

BEAD 22x14.5
250 GR/M
W.T = 11 mm

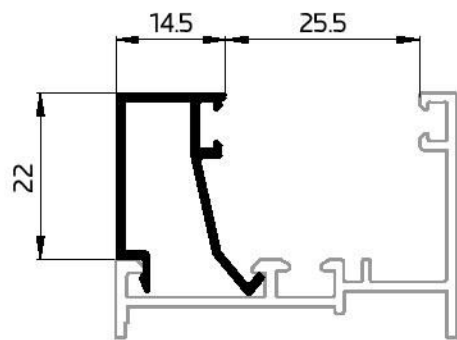

33022

BEAD 22x14.5
238.46 GR/M
W.T-12mm

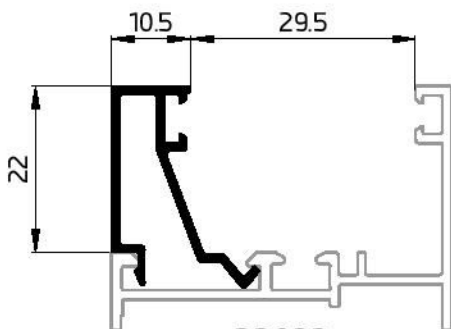

33023

BEAD 22x10.5
235.82 GR/M
W.T-12mm

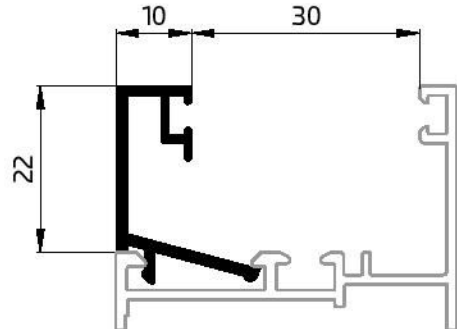

33056

BEAD 22x10
247.36GR/M
W.T = 15 mm

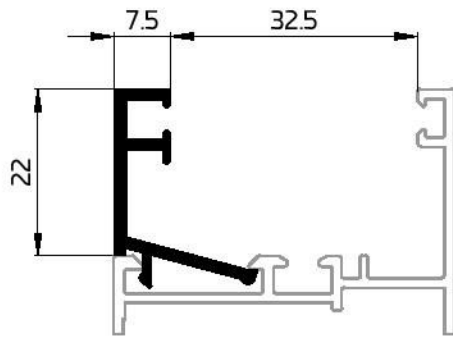

33057
 BEAD 22x7.5
 244.94 GR/M
 W.T = 1.7 mm

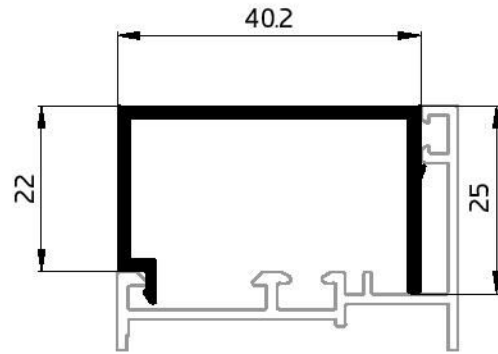

33053
 FRAME CAP
 439.70 GR/M
 W.T = 18 mm

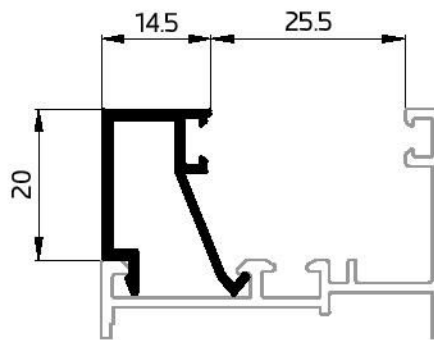

33036
 BEAD 20x14.5
 264.01GR/M
 W.T = 15 mm

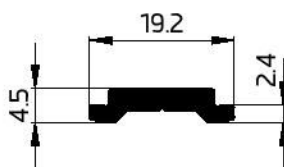

33012
 ESPAGNOLETTE 45
 155.55 GR/M

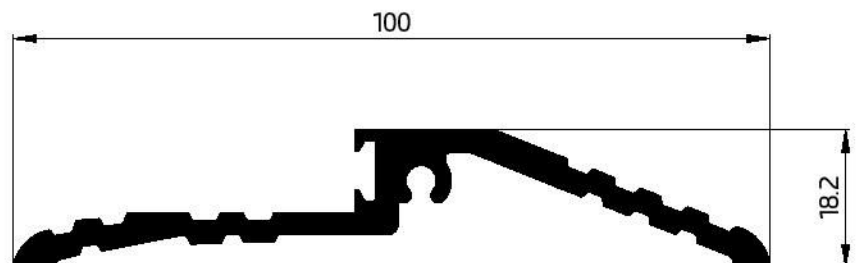

33119
 THRESHOLD 100
 1,124.32 GR/M
 W.T- 3mm

31009
 THRESHOLD 100
 1050 GR/M
 W.T- 2.6mm